

WIREFREE 2-ZONE CONTROLLER

PRODUCT SPECIFICATION SHEET

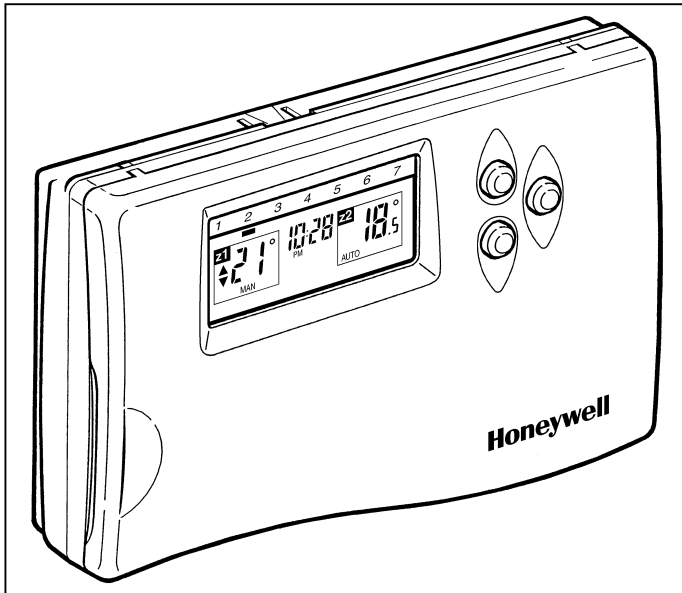

The **CM67^Z** Zone Controller is designed to provide automatic control of heating systems consisting of 2 independent zones. The 7-day program for each zone can be set by customer to suit comfort and functional requirements of a particular zone. The Zone Controller provides setpoint information to HR80 radiator controllers in a zone. The HR80s control the temperature in each room individually and they send the current heat demand to the HC60NG boiler controller. **CM67^Z** controller can also be used to control a zone valve (only in zone 1)

The concept of individual room control at each radiator allows the system to be applied in any installation, no re-plumbing required.

The **CM67^Z** uses reliable RF communication technology in the 868MHz band.

The **CM67^Z** user interface is similar to those of CM67 programmable thermostats. The time/temperature programming philosophy combined with one function-one button operating principle makes this product easy to program and use.

FEATURES

- The **CM67^Z** can be installed without disrupting your room décor – no wired connection required between the room unit, radiator controllers and the boiler controller
- Reliable RF communication utilising 868 MHz band with 1 % duty cycle limit to minimise communication disturbance
- The **CM67^Z** can be used to control a zoning system with 2 zones. Additional room units may be used to extend the system.
- Maximum system efficiency and extended boiler life due to smart boiler feedback mechanism
- One central programming and command point for both zones
- Easy to program – user friendly interface allowing 7-day programming to match variety of lifestyles and zone functions
- Manual override buttons for each zone allow to maintain the constant temperature for the whole day
- Suitable for any room décor due to subtle styling
-  Holiday button provides energy savings by reducing the temperature for 1 to 99 days when homeowner is on holiday, returning to normal operation on the day of return.
- Armchair programmed
- Non volatile memory holds the user program permanently even when batteries being replaced
- Automatic Summer/Winter time change eliminates the need of time adjustment
- When used with the table top stand the room unit can be positioned anywhere in the house where RF communication is reliable
- RF communication test facilitates fast and simple system commissioning
- Installer Set-Up Mode allows extra functions to be set at the discretion of the installer to match the application :
 - Optimisation
 - Minimum boiler ON time
 - Cycle rate
 - Built-in sensor
 - Local temporary override
 - Open-window detection
 - Upper / Lower Setpoint Limit Adjust
 - Temperature offset
 - Proportional Band Width
 - Fail-safe mode for communication loss
- Frost protection is ensured when the slider is in the OFF position.

CM67Z^Z CONTROLS/DISPLAY LAYOUT

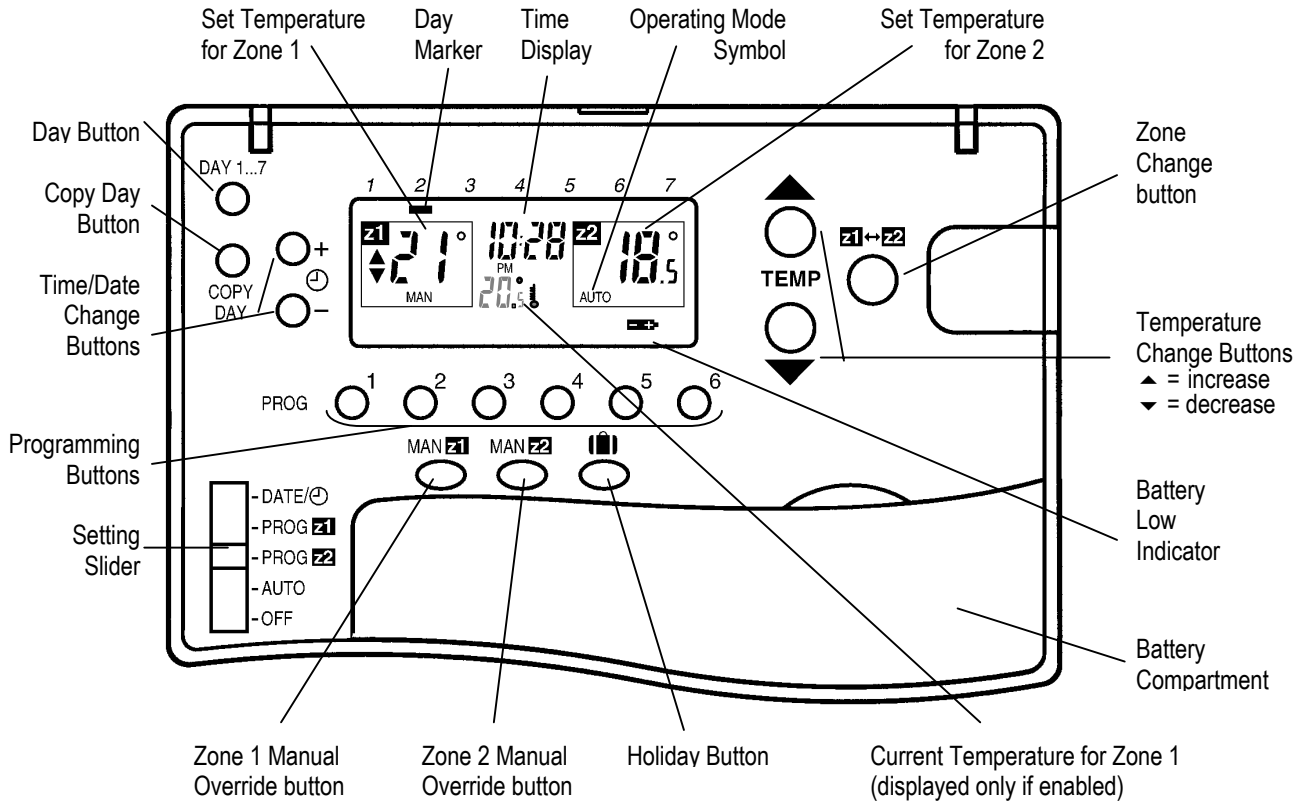

SPECIFICATIONS

ELECTRICAL

- Room unit power : 2 x 1.5 V IEC LR6 (AA) Alkaline cells supply
- Battery life : 2 years typical
- Battery replacement : Program retained in EEPROM
- Receiver power : 230V AC +10% - 15%, 50Hz supply

ENVIRONMENTAL & STANDARDS

- Operating temperature : 0 to 40°C
- Shipping & storage temperature : -20 to 55°C
- Humidity : Humidity range 0 to 90% rh, non-condensing
- IP class : 30
- Meeting the following standards : EN60730-1(2000), EN55014-1(1997), EN55014-2(1997), ETSI EN300 220-3 (2000), ETSI EN301 489-3(2000)

PROGRAMMING/TIME SETTING

- Program : 7-day programs for each zone, 6 daily time and temperature level changes
- Time keeping accuracy : Typically better than 10 minutes per year
- Time setting resolution : Time of day - 1 minute
Program - 10 minute steps
- Temperature setting range : Program : 5 to 30°C in 0.5 °C steps Frost : 5 °C or equal to lower limit (5 °C to 16 °C).
- Room Temperature display range : From 0 °C to 40 °C (Display resolution 0.5°C)

RF

- RF operation band : ISM (868.0-868.6) MHz, 1% duty cycle
- RF communication : 30 m in a residential building environment range
- RF communication : short, high rate transmissions to minimise air time and avoid collisions

INSTALLER SET-UP

This feature allows you to adjust **CM67^Z** to match the specific requirements of the application. Installer Set-up allows to:

- Set-up specific applications parameters
- Enable special features
- Configure zoning system operation

Special Features	Description	Setting
Optimisation - Adaptive Intelligent Recovery TM 1:OP	The CM67^Z will adjust the start time at upward setpoint changes so the desired temperature is reached at the programmed time e.g 7:00 temperature 21°C. The chronotherm will monitor the start-up period and use this information to modify the start time calculation for the next upward setpoint change. The system will restrict the start time to a max of 3 hours before the programmed comfort time	0* – disabled 1 – enabled
Minimum boiler On time 2:Ot	Defines the minimum switch on and off time for the boiler. The selected value is transferred via RF communication to HC60NG and is used as the key boiler control parameter	1 min (other values: 2, 3, 4, 5)
AM-PM/ 24hr Display 3:Cl	Change display format (default 24hr)	0* – 24 hr display 1 – AM/PM display
Internal temperature sensor 7:tS	Allows configuring of the CM67^Z to use its own build in sensor to measure the temperature in zone1. The measured values is used by all HR80 is zone1. When built-in sensor is disabled will also display the measured temperature.	0* - disabled 1 – enabled
Cycle rate 9:Cr	Determines the length of boiler cycle. The selected value is transferred via RF communication to HC60NG and is used as the key boiler control parameter	6 cph (10 min)* (other values: 3, 9)
System Timing Master 10:St	To ensure synchronous operation of the boiler and zone valves (controlled by HC60NG) in the system one of the CM67^Z has to be configured as the system timing master sending the sync signal co-ordinating on/off cycling of all HC60NGs.	0* – normal operation 1 – system timing master
Fail-safe mode 16:LC	The CM67^Z allows you to set the fail-safe mode of operation of the heating system if radio communication is lost. By default HC60 boiler controller relay will be switched OFF in case of communication loss. Alternatively you may choose to cycle the boiler at 2 min ON and 8min OFF. Useful when the building is not occupied for long periods of time and there is a high risk of frost damage.	0* – relay OFF 1 – relay cycles
Zone valve control enable 17:CE	Allows sending a special message to control HC60NG operating as zone valve controller. In this way flow in the whole zone can be controlled with just one valve. This type of control can only be used for zone 1	0* - disabled 1 – enabled
Open window detection function 18:Ho	According to factory default operation HR80 controller will close the valve when open window is detected. This parameter allows configuring the HR80 to perform or ignore this function.	3* - enabled 0 - disabled in zone 1 & 2 1 - enabled in zone 1 2 – enabled in zone 2
HR80 local override 19:HL	According to factory default local override of HR80 setpoint is enabled. This parameter allows disabling this function if required.	3* - enabled 0 - disabled in zone 1 & 2 1 - enabled in zone 1 2 – enabled in zone 2

* - factory default values

APPLICATIONS OVERVIEW

The **CM67Z** was designed to provide control of residential zoning system in variety of installation. It can be used for system with vertical heat distribution as well as for the ones with manifolds. Re-plumbing of the installation is not required.

The diagrams below show how **CM67Z** zone controller can be used with other Honeywell products (such as HR80 radiator controller or HC60NG boiler controller) to control a zoning system

Multi-apartment block – 2-zone system, no boiler feedback)

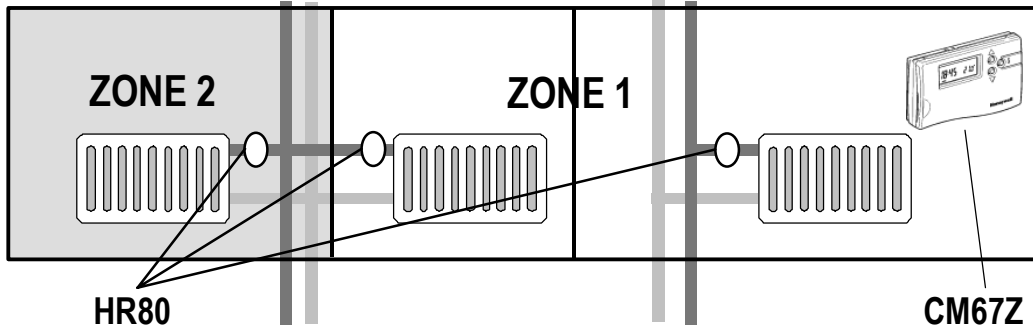

System Specification Example

	y	
CM67Z (T6667ZXXXX)	1	2-zone RF unit, 2 independent 7-day programs per zone
HR80	m	RF radiator controllers for zone 1
HR80	n	RF radiator controllers for zone 2
TRV's (valve bodies)	m+n	Thermostatic radiator valves
Optionally		
HR80 adapter	m+n	Required for Oventrop, Herz, Danfoss and Vaillant valves

m – number of radiators in zone 1, n – number of radiators in zone 2

Single family house – 2-zone system with boiler feedback

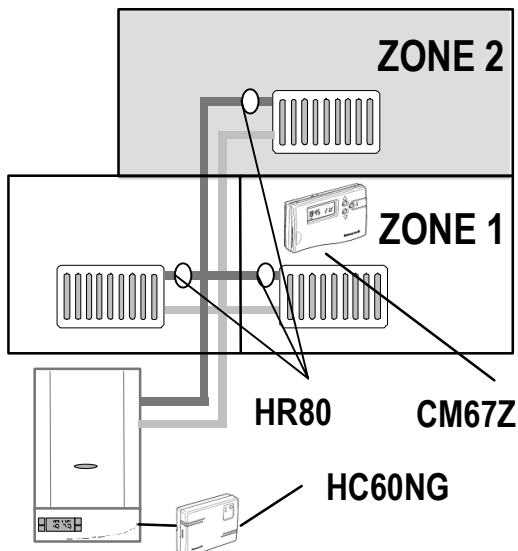

System Specification Example

OS Number	Quantity	Description
CM67Z (T6667ZXXXX)	1	2-zone RF unit, 2 independent 7-day programs per zone
HC60NG (R6660DXXXX)	1	Intelligent boiler controller
HR80	m	RF radiator controllers for zone 1
HR80	n	RF radiator controllers for zone 2
TRV's (valve bodies)	m+n	Thermostatic radiator valves
Optionally		
HR80 adapter	m+n	Required for Oventrop, Herz, Danfoss and Vaillant valves

m – number of radiators in zone 1, n – number of radiators in zone 2

ZONING FUNCTIONALITY

Zoning system control is achieved by co-ordinated action of the room unit, radiator controllers and boiler controller. The zoning control system consists of the following components:

1. Zone Controller (**CM67^Z**)- allows time and temperature programming for each zone. Sends setpoint signal to the HR80 radiator controllers in both zones. The **CM67^Z** can also be used to control HC60NG zone valve controller.
2. Radiator Controller (HR80) – measures and controls the room temperature, receives the setpoint from the zone controller, sends a demand signal to the HC60NG controlling the boiler. Optionally HR80 can also receive the room temperature signal from the **CM67^Z**
3. Boiler Controller (HC60NG) - receives the signals from all HR80s in the system, calculates boiler on time to satisfy the heat demand in the whole house

DIMENSIONS

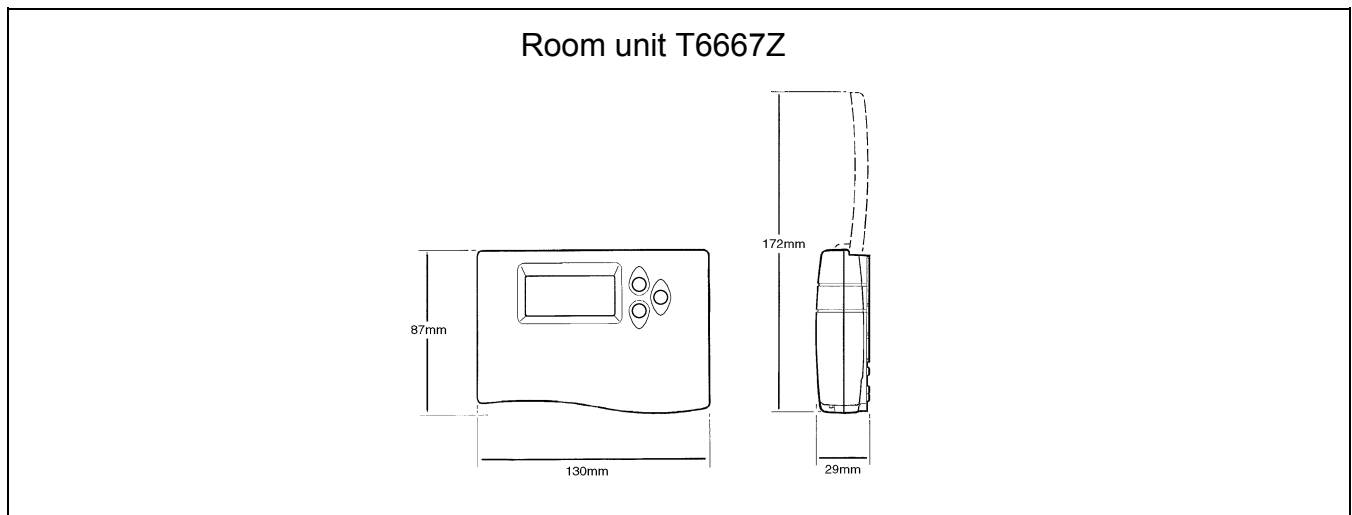

ORDERING SPECIFICATION

Description	Model	Logo	Literature	Spec Sheet
CM67^Z Zone Controller	Y6667Z1007	Honeywell	EN	ENOR8534
Boiler Controller (HC60NG)	R6660D1009	Honeywell	EN, GE	ENOR8535
RF Radiator Controller	HR80	Honeywell	EN, GE, FR, NL, IT, SP	ENOH0445 GE51R0303

INSTALLATION

The CM67Z is a radio frequency device and for the best performance should be installed in an open space. Leave at least 30cm distance from any metal objects including wall boxes and at least 1 metre from any other electrical equipment e.g. radio, TV, PC etc.

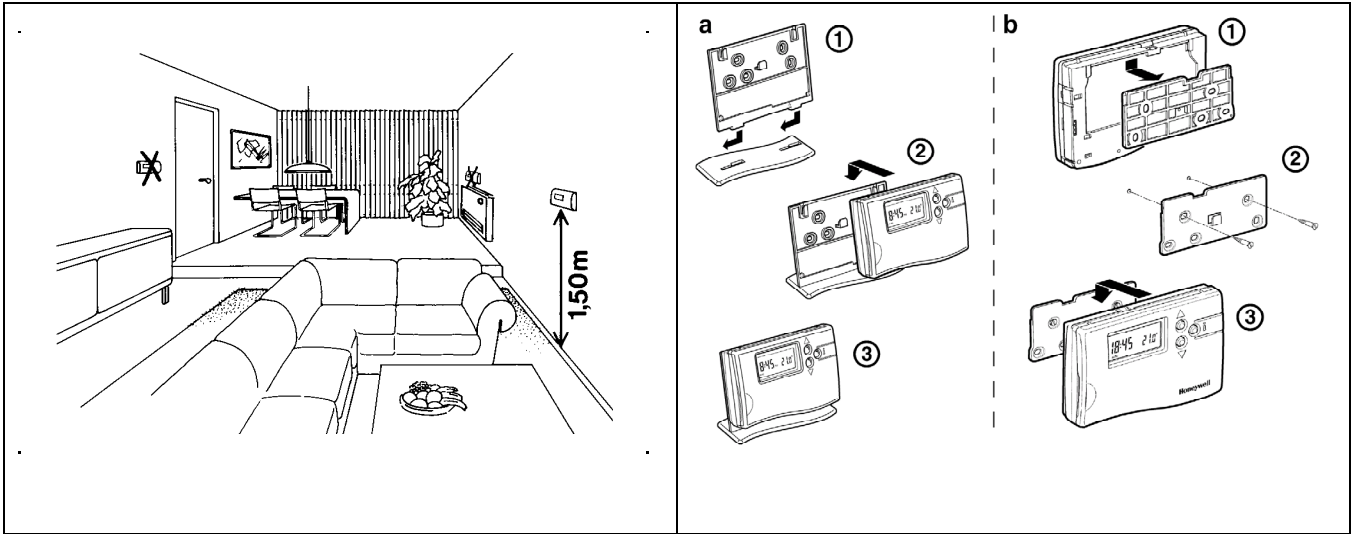

NOTE: If the room unit location is changed (e.g. when using the tabletop stand) always make sure that RF communication in the new locations is reliable.

Honeywell